

Transport GX21

B5350

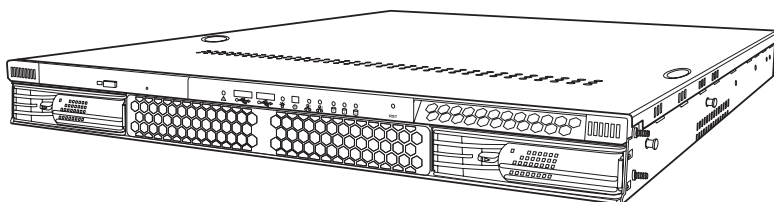

User's Manual

WARNING!

This product should be serviced only by qualified service engineers. Do not remove the chassis cover or attempt to service this product unless you are qualified to do so. Once the chassis cover is removed, there is a risk of electric shock that could lead to serious injury or death.

Preface

Copyright

This publication, including all photographs, illustrations, and software, is protected under international copyright laws, with all rights reserved. Neither this manual, nor any material contained herein, may be reproduced without written consent of the manufacturer.

Copyright 2003-4

Version 1.00

Disclaimer

Information contained in this document is furnished by TYAN computer Corporation and has been reviewed for accuracy and reliability prior to printing. TYAN assumes no liability whatsoever, and disclaims any express or implied warranty, relating to sale and/or use of TYAN products including liability or warranties relating to fitness for a particular purpose or merchantability. TYAN retains the right to make changes to product descriptions and/or specifications at any time, without notice. In no event will TYAN be held liable for any direct or indirect, incidental or consequential damage, loss of use, loss of data or other malady resulting from errors or inaccuracies of information contained in this document.

Trademark recognition

All registered and unregistered trademarks and company names contained in this manual are property of their respective owners including, but not limited to the following.

TYAN, TYAN Tiger i7501R (5350), and Transport GX21 are trademarks of TYAN Computer Corporation.

Intel, Xeon, and combinations thereof are trademarks of Intel Corporation.

Phoenix, PhoenixBIOS, and combinations thereof are trademarks of Phoenix Technologies Ltd.

Microsoft Windows is a trademark of Microsoft Corporation.

IBM, PC, AT and PS/2 are trademarks of IBM Corporation.

Winbond is a trademark of Winbond Electronics Corporation.

Portable Document Format (PDF) is a trademark of Adobe Corporation.

Federal Communications Commission



Notice for the USA Compliance Information Statement (Declaration of Conformity Procedure) DoC
FCC Part 15: This device complies with part 15 of the FCC Rules

Operation is subject to the following conditions:

- 1) This device may not cause harmful interference, and
- 2) This device must accept any interference received including interference that may cause undesired operation. If this equipment does cause harmful interference to radio or television reception, which can be determined by turning the equipment off and on, the user is encouraged to try one or more of the following measures:
 - Reorient or relocate the receiving antenna.
 - Increase the separation between the equipment and the receiver.
 - Plug the equipment into an outlet on a circuit different from that of the receiver.

Consult the dealer on an experienced radio/television technician for help.

Notice for Canada

This apparatus complies with the Class B limits for radio interference as specified in the Canadian Department of Communications Radio Interference Regulations. (Cet appareil est conforme aux norms de Classe B d'interference radio tel que specifie par le Ministere Canadien des Communications dans les reglements d'interference radio.)



Notice for Europe (CE Mark) This product is in conformity with the Council Directive 89/336/EEC, 92/31/EEC (EMC).

CAUTION: Lithium battery included with this board. Do not puncture, mutilate, or dispose of battery in fire. Danger of explosion if battery is incorrectly replaced. Replace only with the same or equivalent type recommended by manufacturer. Dispose of used battery according to manufacturer instructions and in accordance with your local regulations.

About this manual

This manual provides you with instructions on installing your Transport GX21 (B5350), and consists of the following sections

Chapter 1:

Provides an introduction to the Transport GX21 (B5350) bare bones, packing list, describes the external components, gives tables of key components, and provides block diagrams of the system.

Chapter 2:

Covers procedures on installing the CPUs, memory modules, optional PCI card, and hard drives.

Chapter 3:

Covers removal and replacement procedures for pre-installed components.

Appendix:

Provides detailed specifications, maintenance and troubleshooting procedures, an explanation of BIOS and technical diagrams.

Safety information

Before installing and using the Transport GX21 , take note of the following precautions:

- Read all instructions carefully.
- Do not place the unit on an unstable surface, cart or stand.
- Do not block the slots or openings on the unit which are provided for ventilation.
- Only use the power source indicated on the marking label. If you are not sure, contact the power company.
- The unit uses a three-wire grounded cable, which is supplied with a third pin to ground the unit and prevent electric shock. Do not defeat the purpose of this pin. If your outlet does not support this type of plug, contact an electrician to replace the obsolete outlet.
- Do not place anything on the power cord. Place the power cord where it will not be stepped on.
- Follow all warnings and cautions in this manual and on the unit case.
- Do not push objects in the ventilation slots as they may touch high voltage components and result in shock and damage to the components.
- When replacing parts, ensure that you use parts specified by the manufacturer.
- When service or repairs have been carried out, perform routine safety checks to verify that the system is operating correctly.
- Avoid using the system near water, in direct sunlight, or near a heating device.
- Cover the unit when not in use.

Overview

About the Transport GX21 (B5350)	1
Product models	1
Features	2
B5350G21S2H specifications	2
Box contents	3
Accessories	4
Opening the box	5
About the product	6
System front view and front panel	6
System rear view	6
System internal views	7

Setting up

Before you begin	9
Work area	9
Tools	9
Precautions	10
Installing motherboard components	11
Removing the chassis cover	11
Installing CPUs	12
Installing memory	15
Installing a PCI card	16
Installing a hard drive	20
Installing an external S-ATA hard drive	20
Rack mounting	23

Replacing installed components

Introduction	27
Replacing motherboard components	27
Disconnecting all motherboard cables	27
Replacing the motherboard	30
Replacing the CD-ROM drive	31
Replacing the LED control board	32
Replacing the storage backplane	33
Replacing the power supply	36
Replacing the cooling fans	37

Appendix

BIOS	39
Technical support	63

Chapter 1: Overview

1.1 About the Transport GX21 (B5350)

Congratulations on your purchase of the Transport GX21 (B5350), rack mountable, barebone system for Intel® Xeon™ processor. The Transport GX21 (B5350) uses an advanced Intel chipset for optimum performance and reliability. The add-on S-ATA storage controller provides great flexibility and is combined with Gigabit Ethernet ports to provide powerful computing capacity and optimal I/O bandwidth for the most demanding of enterprises.

The rugged, industry standard 19-inch, rack mountable design contains up to 2 HDD bays, 1 slim CD-ROM bay option, making it both flexible and practical.

1.2 Product models

Model	HDD	Hot Swap Support	HDD Back-plane	SKU Type
B5350G21S2H	2 removable HDD bays	Yes	2 port S-ATA	Standard SKU







1.3 Features

1.3 Features

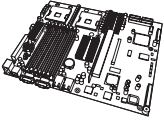
1.3.1 B5350G21S2H specifications

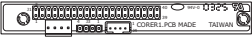
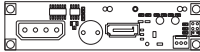
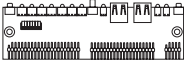

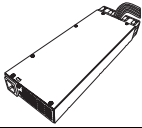
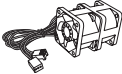

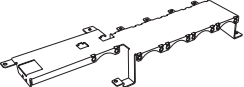

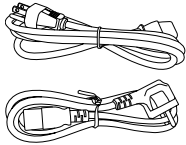
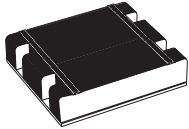
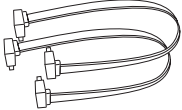

Enclosure <ul style="list-style-type: none">• Industry standard, 19" rack mountable, 1U chassis• 2 hot swappable HDDs• 1 slim CD-ROM bay• 21.5 x 17 x 1.73 inch (546 x 432 x 44 mm)	Storage <ul style="list-style-type: none">• Dual channel IDE (CD-ROM)• Integrated Serial ATA (6300ESB), support for 2 SATA ports, RAID 0,1• Support for up to 2 hot-swappable SATA 1.0 HDD
Processors <ul style="list-style-type: none">• Dual mPGA604pin ZIF sockets• Single or dual Intel® Xeon™ (Nacona) processor• 800 MHz FSB	Cooling <ul style="list-style-type: none">• 4 cooling fans (40 x 40 x 56 mm)• 1 cooling fans (40 x 40 x 28 mm)• 2 passive CPU heatsinks
Chipset <ul style="list-style-type: none">• Intel® Lindhurst-VS (E7320) MCH• Intel Hance Rapids (6300ESB) Southbridge• SMSC DME1737 LPC I/O chip• Analog Devices ADM1027 hardware monitoring IC	Motherboard <ul style="list-style-type: none">• Tyan Tiger i7510 S5350 motherboard• ATX form factor• Phoenix BIOS on 8 Mb LPC flash ROM
Memory <ul style="list-style-type: none">• Dual channels, (8) DIMM sockets• Support for up to (6) DDR333 or (8) DDR266• Up to 16 GB of registered DDR• Support for ECC type memory modules	Networking <ul style="list-style-type: none">• 2 Gigabit Ethernet ports (Broadcom BCM5721PCI-E GbE LAN controller connected MCH), with teaming feature support
Expansion slots <ul style="list-style-type: none">• (1) 64-bit, 66 MHz PCI-X slot on riser card	Power supply <ul style="list-style-type: none">• EPS 12V, 1U, 500W with PFC
Back I/O ports <ul style="list-style-type: none">• Stacked PS/2 mouse and keyboard ports• 2 USB 2.0 ports• 1 9-pin UART serial port• 2 RJ-45 LAN ports• 1 VGA port	Video <ul style="list-style-type: none">• ATI® Rage™ XL PCI Graphics controller• 8 MB frame buffer video memory
Front panel <ul style="list-style-type: none">• 2 USB 2.0 ports• HDD activity, Warning/Fail, LAN activity, and power LEDs• Power and reset switches	Regulatory <ul style="list-style-type: none">• FCC class B (declaration of conformity)• CE (declaration of conformity)

1.3.2 Box contents

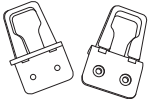
Diagram	Component
	1U chassis, 2 external HDD bays
	Tyan S5350 system board (pre-installed)
	Slim CD-ROM adapter
	24x slim CD-ROM drive (pre-installed)
	Slim FDD adapter
	S-ATA backplane and holding bracket (pre-installed)
	LED control board (pre-installed)
	64-bit riser card (pre-installed)
	EPS 12V 500W PSU (pre-installed)
	15,500 rpm cooling fan (4 pcs - 40 x 40 x 56 mm)
	15,000 rpm cooling fan (1 pcs - 40 x 40 x 28 mm)
	Fan holding bar

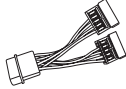
1.3 Features

1.3.3 Accessories

 <p>Power cords (US/German)</p>	 <p>2 x CPU heatsinks P/N 343734800001</p>
 <p>2 x S-ATA cables, motherboard to backplane</p>	 <p>2 x Sliding rails P/N 341730200001</p>
 <p>2 x mounting ears</p>	 <p>1 x 40 pin IDE cable for CD-ROM (B5350G21S2H only)</p>
 <p>S-ATA power riser cable</p>	 <p>B5350G21S2H Tyan and Intel 6300 ESB S-ATA RAID driver disk and CD</p>
 <p>Motherboard quick reference guide and user's manual</p>	 <p>Transport GX21 (B5350) hardware installation guide</p>

1.3.4 Opening the box

Open the box carefully and ensure that all components are present and undamaged. The product should arrive packaged as illustrated below.

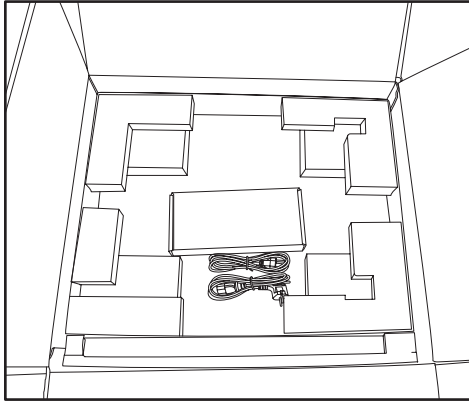

Box contents as packaged

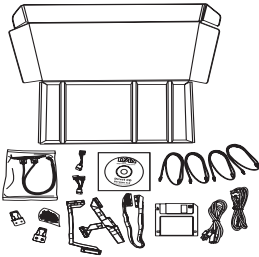

Accessory pack

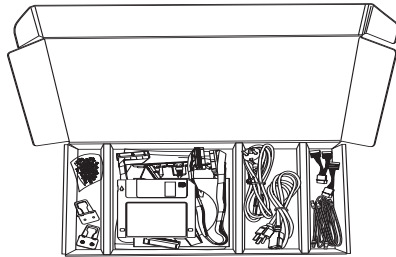

Accessories as packaged

1.4 About the product

1.4 About the product

1.4.1 System front view and front panel

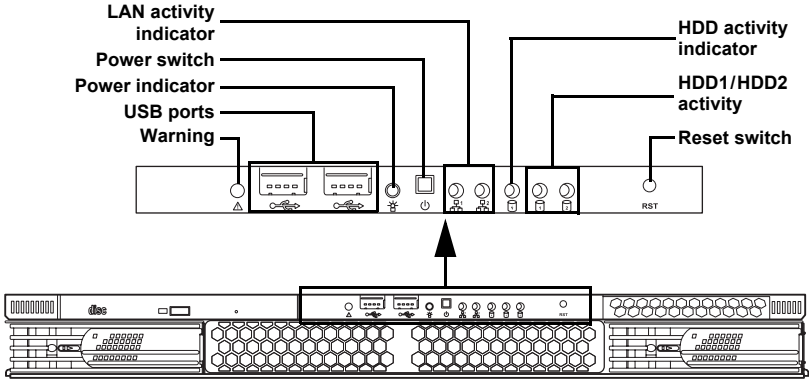

1.4.2 System rear view

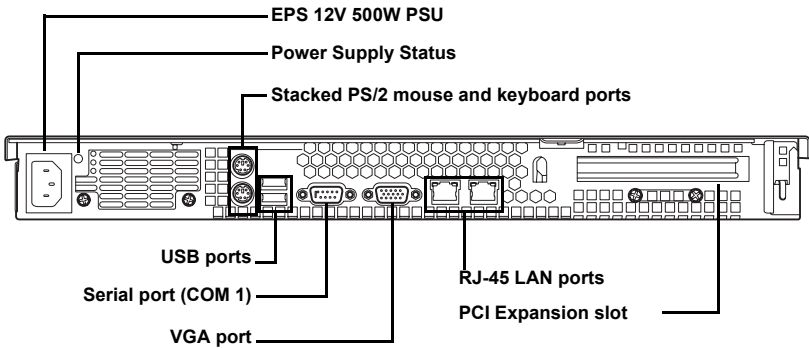

Power supply status

A single bi-colored LED indicating power supply status as described below.

LED	Power Supply Condition
Off	No AC power to all power supplies
Amber	Power supply critical event causing a shutdown; failure, OCP, OVP, Fan Fail.
Blinking Amber	Power supply warning events where the power supply continues to operate: high temp, high power, high current, slow fan.
Blinking Green	AC present/Only 5VSB on (PS off)
Green	Output ON and OK

1.4.3 System internal views

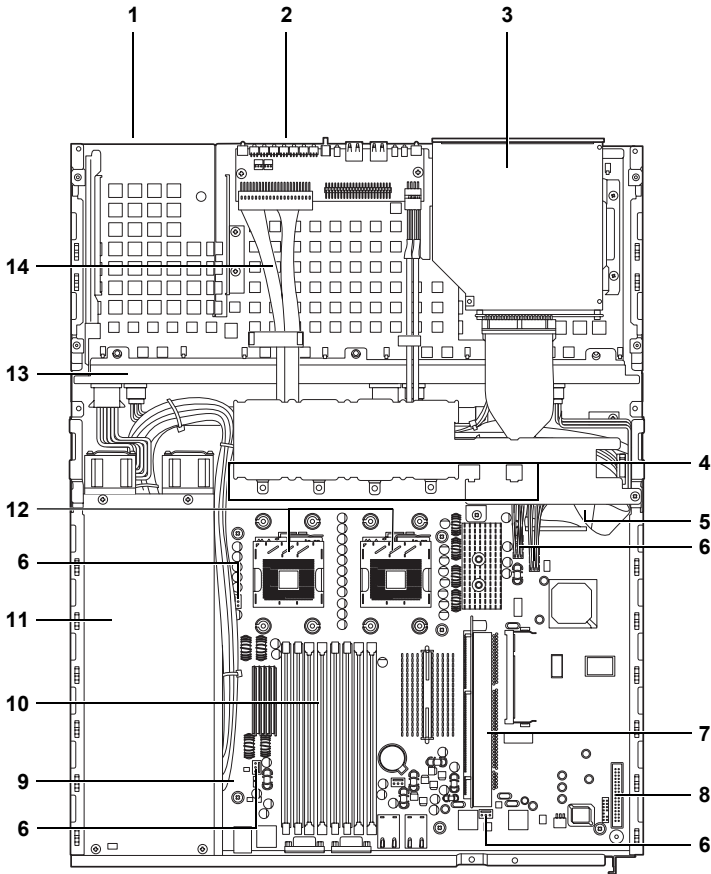

1	Floppy disk drive bay	8	FDD connector
2	LED control board	9	Power connector (located underneath the cabling)
3	Slim CD-ROM drive	10	Memory slots
4	Fan bracket	11	EPS 12V 500W power supply
5	IDE connector (located underneath the fan bracket)	12	Processor sockets
6	Fan connectors	13	1-port S-ATA backplane board x 2pcs
7	Riser card	14	Front panel cables

1.4 About the product

Block diagram

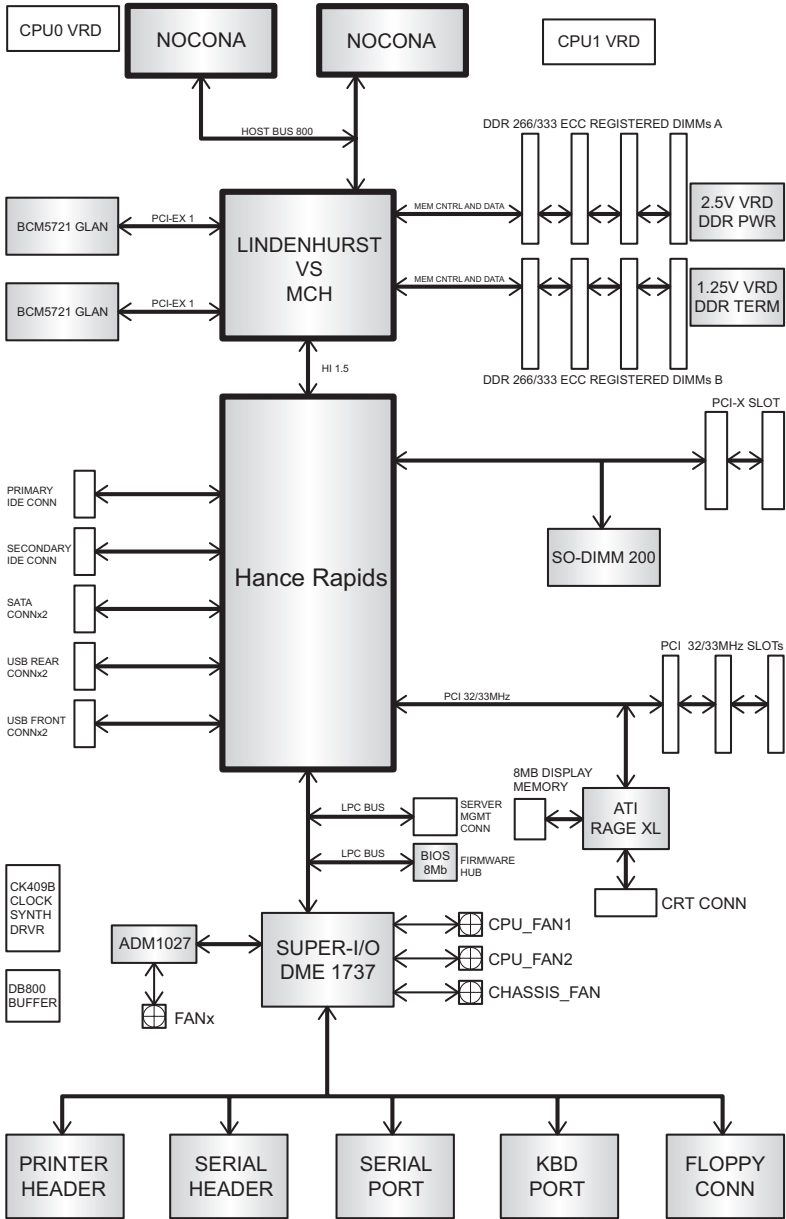

Chapter 2: Setting up

2.1 Before you begin

This chapter explains how to install motherboard components including CPUs, memory modules, and PCI cards. There are also instructions in this section for installing S-ATA and IDE hard drives.

Careful attention should be given to the precautions mentioned in this section when setting up your system.

2.1.1 Work area

Make sure you have a stable, clean working environment. Dust and dirt can get into components and cause malfunctions. Use containers to keep small components separated. Putting all small components in separate containers prevents them from becoming lost. Adequate lighting and proper tools can prevent you from accidentally damaging the internal components.

2.1.2 Tools

The following tools will be required to complete the installations described in this chapter.

- A cross head (Phillips) screwdriver
- A grounding strap and/or anti static pad

Most of the electrical and mechanical connectors in your system can be disconnected using your fingers. It is recommended that you do not use needle-nosed pliers to remove connectors as these can damage the soft metal or plastic parts of the connectors.

2.1 Before you begin

2.1.3 Precautions

Components and electronic circuit boards can be damaged by static electricity. Working on a system that is connected to a power supply can be extremely dangerous. Follow the guidelines below to avoid damage to the Transport GX21 or injury to yourself.

- Ground yourself properly before removing the top cover of the system. Unplug the power from the power supply and then touch a safely grounded object to release static charge (i.e. power supply case). If available, wear a grounded wrist strap. Alternatively, discharge any static electricity by touching the bare metal chassis of the unit case, or the bare metal body of any other grounded appliance.
- Avoid touching motherboard components, IC chips, connectors, memory modules, and leads.
- The motherboard is pre-installed in the system. When removing the motherboard, always place it on a grounded anti-static surface until you are ready to reinstall it.
- Hold electronic circuit boards by the edges only. Do not touch the components on the board unless it is necessary to do so. Do not flex or stress circuit boards.
- Leave all components inside the static-proof packaging that they ship with until they are ready for installation.
- After replacing optional devices, make sure all screws, springs, or other small parts are in place and are not left loose inside the case. Metallic parts or metal flakes can cause electrical shorts.
- Always use the correct size screws and fixings when installing or replacing components.

Note: All connectors are designed to fit one way only, no force should be required to make a connection.

2.2 Installing motherboard components

This section describes how to install CPUs, memory modules and PCI card.

2.2.1 Removing the chassis cover

Follow these instructions to remove the Transport GX21 (B5350) chassis cover. This step is required before any other procedures in this chapter can be undertaken.

1. Remove the four screws that secure the chassis cover.

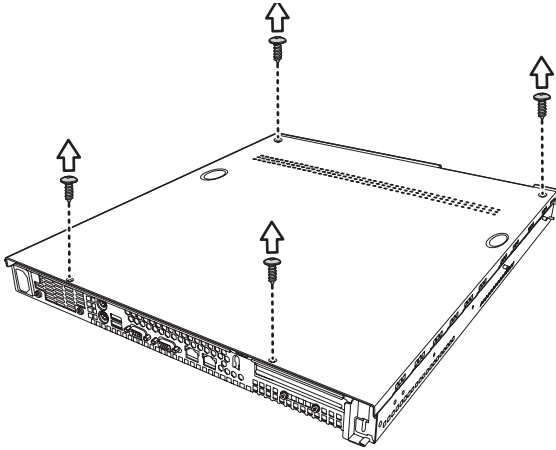

2. Slide the cover in the direction of the arrow (A) and then lift the cover off (B).

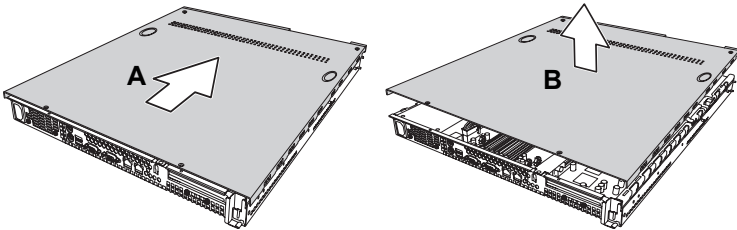

2.2 Installing motherboard components

2.2.2 Installing CPUs

This section describes how to install Intel® Xeon processors and heatsinks in your Transport GX21 (B5350) system. This section applies to all models.

1. Remove the chassis cover as described in section 2.2.1 *Removing the chassis cover*.
2. Locate the CPU sockets on the motherboard as shown below.

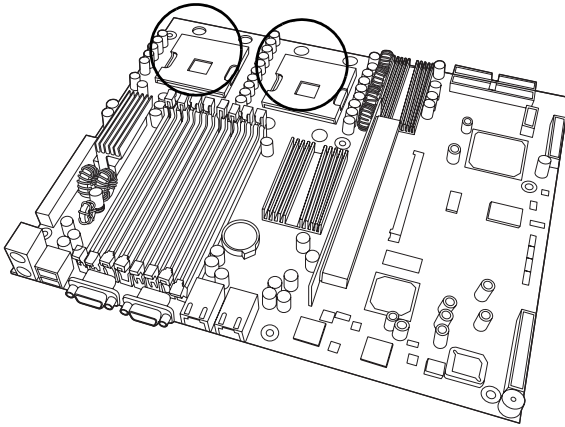

3. Turn the motherboard upside down to install the heat sink springs, in the order shown. See 3.2.2 *Replacing the motherboard* for instructions on how to remove the motherboard.

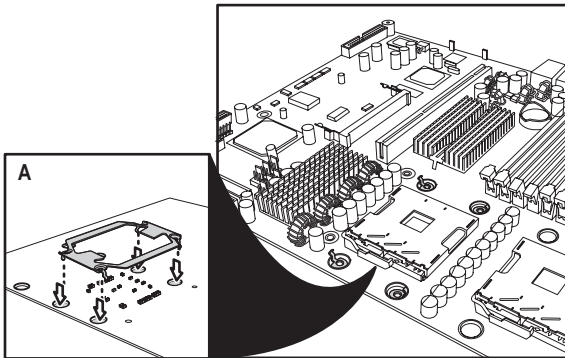

2.2 Installing motherboard components

4. Lift the CPU locking lever as shown below.

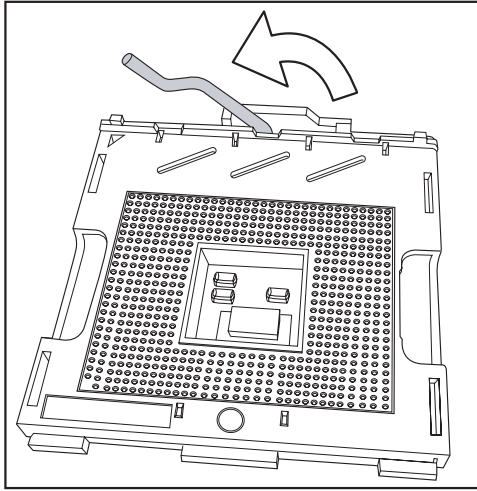

5. Place the CPU in the CPU socket, ensuring that pin 1 is located as shown in the following illustration.

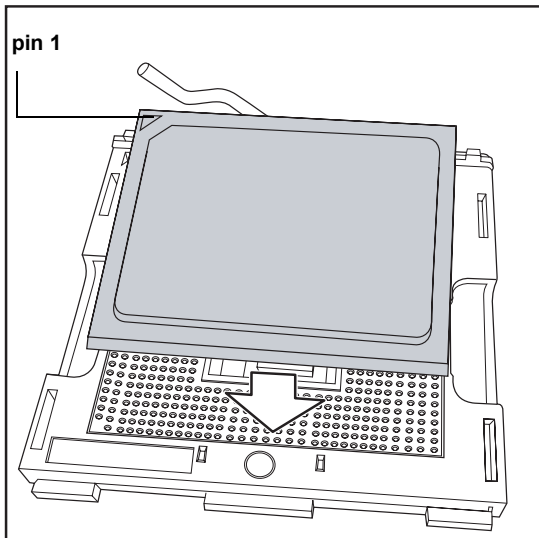

6. Press the CPU locking lever back down to secure the CPU in the socket.
7. Repeat steps three to six for the second CPU.
8. Apply thermal grease to the top of the CPUs and place the CPU heatsinks on the CPUs.

2.2 Installing motherboard components

9. Tighten the four screws to secure the heatsinks in place as shown below.

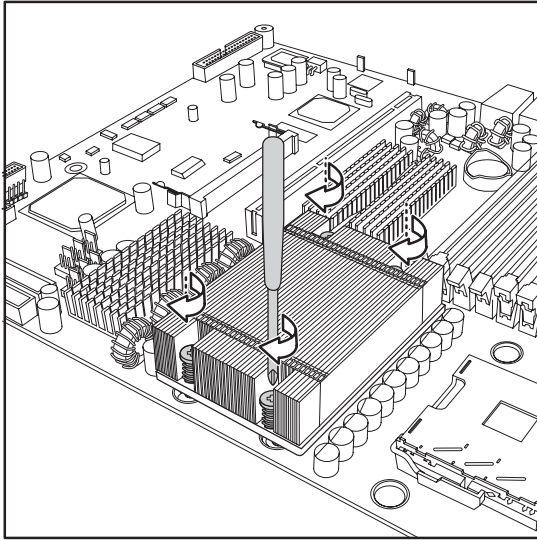

Note: CPU heatsinks must be removed to install or remove memory modules.

2.2 Installing motherboard components

2.2.3 Installing memory

Follow the instructions in this section to install memory modules in your Transport GX21 (B5350) system.

1. Remove the chassis cover as described in section 2.2.1 *Removing the chassis cover*.
2. Locate the memory slots on the motherboard.

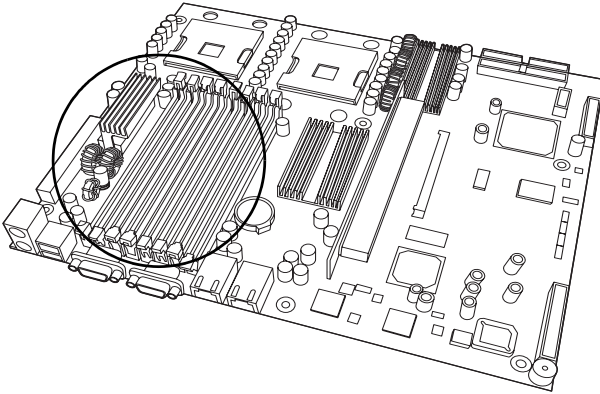

3. Press the memory slot locking levers in the direction of the arrows as shown below.

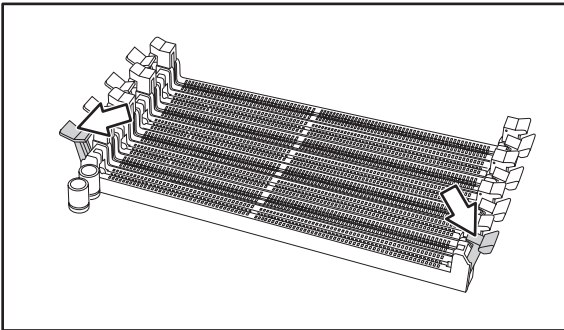

Note: It is not possible to move the memory slot locking levers without first removing the CPU heatsinks.

4. Align the memory module with the slot. The module will fit only one way in the slot. Ensure that indentations in the memory module line up with corresponding notches in the memory slot.

2.2 Installing motherboard components

5. Insert the memory module into the slot as shown.

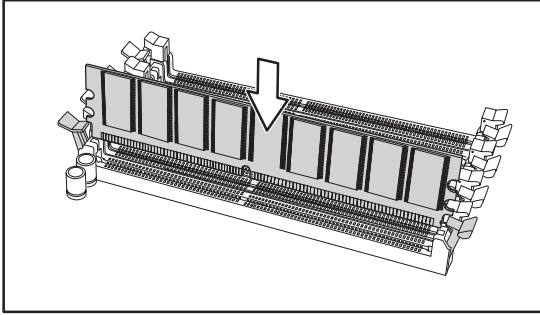

6. Ensure that the locking levers are firmly in place and that the memory module is properly seated in the slot.

2.2.4 Installing a PCI card

Follow the instructions in this section to install a PCI card in your Transport GX21 (B5350) system.

1. Remove the chassis cover as described in section 2.2.1 *Removing the chassis cover*.
2. Remove the PCI retention bar.

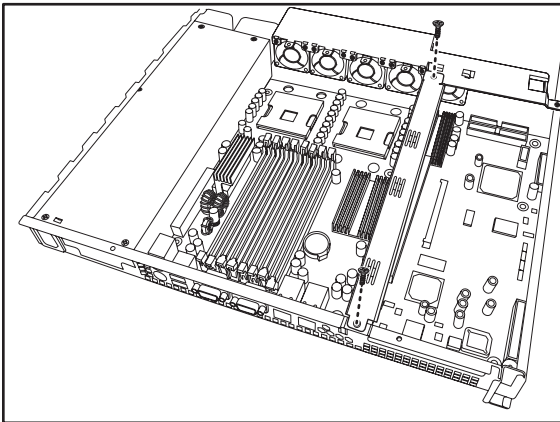

2.2 Installing motherboard components

3. Remove the screw securing the PCI faceplate to the chassis.

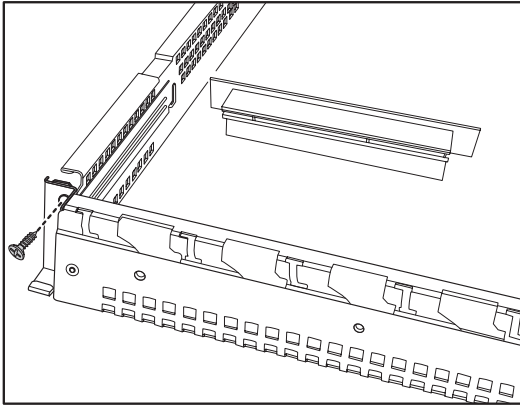

4. Slide the PCI card clamp out as shown.

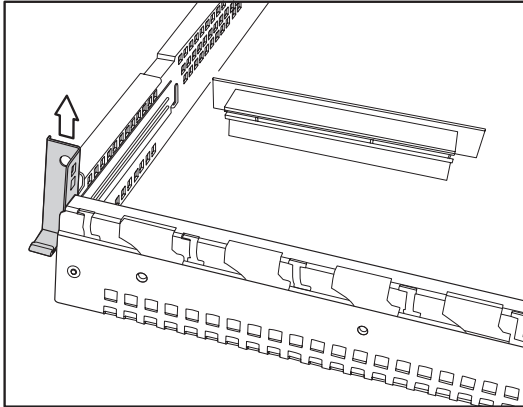

5. Slide the dust cover out.

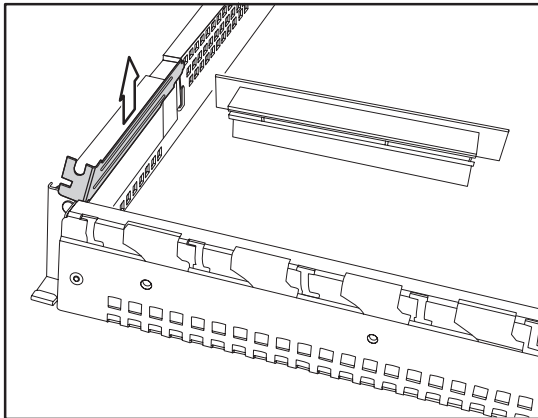

2.2 Installing motherboard components

6. Press the PCI card into place in the slot on the riser card. Ensure that the card is seated properly in the slot on the riser card and that the riser card is properly seated in its slot on the motherboard.

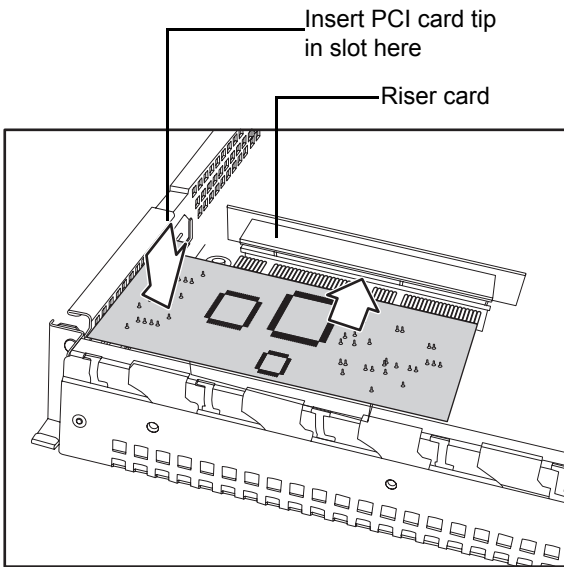

7. Reinsert the PCI card clamp.

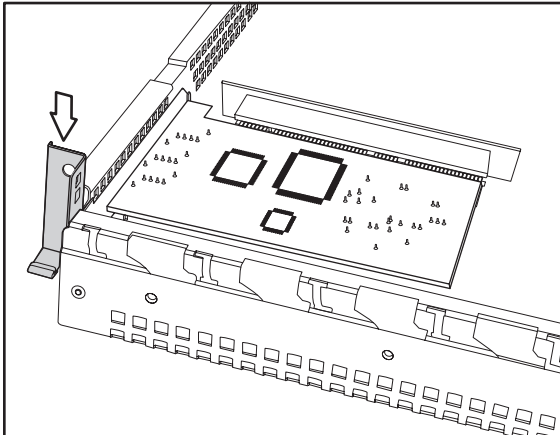

2.2 Installing motherboard components

8. Insert the screw to secure the PCI card to the chassis.

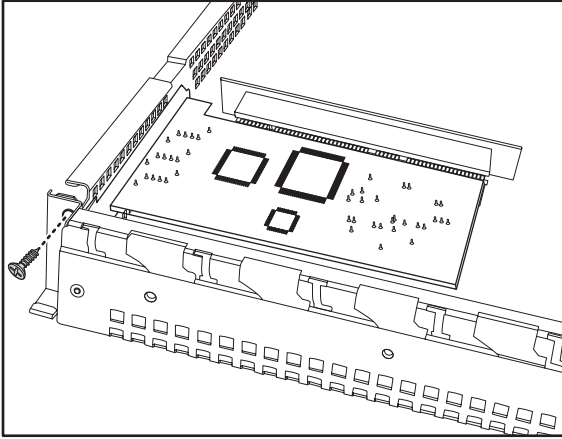

2.3 Installing a hard drive

2.3 Installing a hard drive

Follow these instructions to install hard drives in your system.

2.3.1 Installing an external S-ATA hard drive

Follow these instructions to install an external S-ATA hard drive in your system.

1. Remove the chassis cover as described in section 2.2.1 *Removing the chassis cover*.
2. Press the drive bay locking latch in the direction of the arrow **(A)** and pull the locking lever open **(B)**.

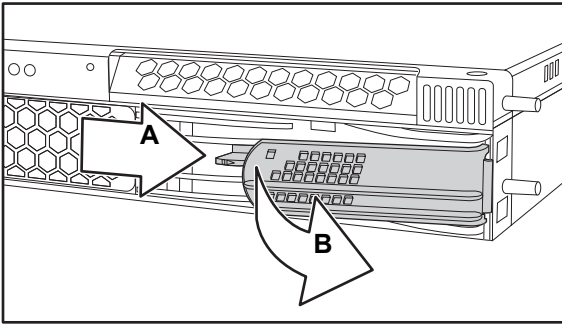

3. Slide the drive bay out.

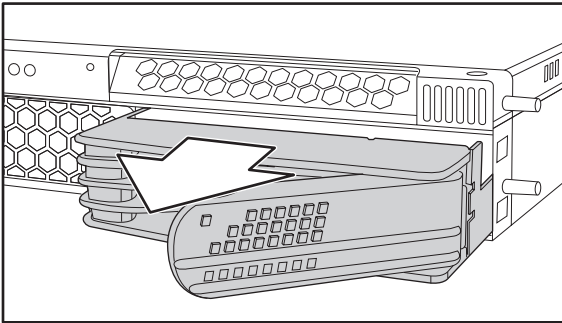

2.3 Installing a hard drive

4. Place a S-ATA drive in the drive bay.

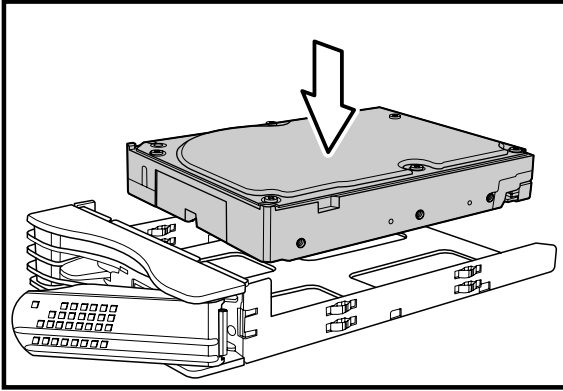

Note: If you are replacing an existing HDD, you will need to remove the four screws that secure it in the drive bay and remove it.

5. Insert four screws to secure the new unit in the drive bay.

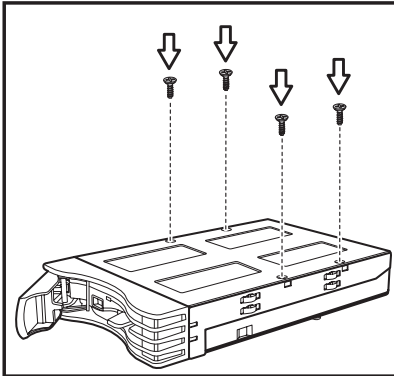

2.3 Installing a hard drive

6. Reinsert the drive bay into the chassis. Ensure that the rear connector of the new drive is firmly seated in the backplane.

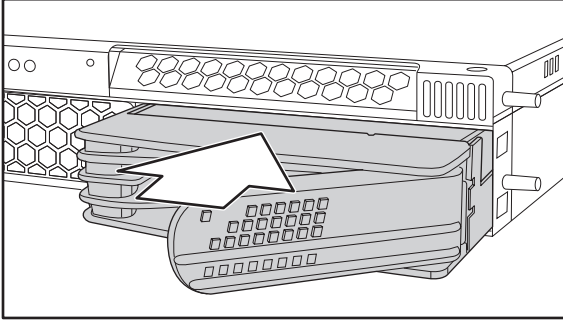

2.4 Rack mounting

Follow these instructions to mount the Transport GX21 (B5350) into an industry standard 19" rack.

Note: Before mounting the Transport GX21 in a rack, ensure that all internal components have been installed and that the unit has been fully tested. Maintenance can be performed on the unit while in a rack but it is preferable to install the device in a fully operational condition.

1. Screw the mounting ears to the Transport GX21 as shown using 4 screws from the supplied nuts, screws and washers kit.

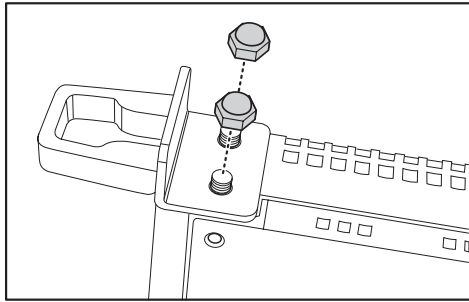

2. Screw the sliding rail mounting brackets to the sliding rails as shown, using the short black screws from the supplied nuts, screws and washers kit.

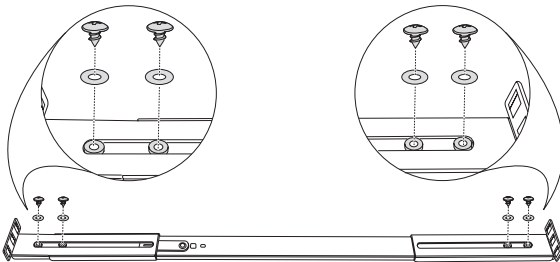

Note: Ensure that the brackets with the cut away section (to accommodate the handles on the front of the unit) are fixed to the front end of the rail.

3. Fully extend the sliding rails until they lock.

2.4 Rack mounting

Note: Do not tighten the brackets to the rails as you will need to adjust their position later.

4. Screw each sliding rail to the side of the Transport GX21 as shown. You will need 3 short, silver colored screws from the supplied nuts, screws and washers kit, for each rail.

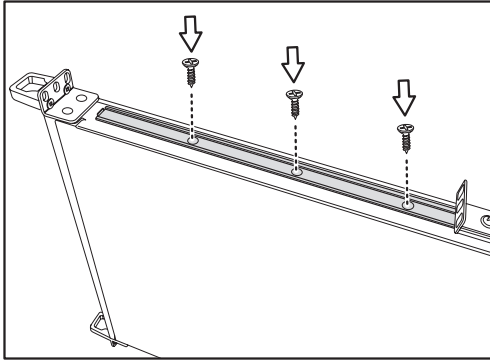

5. Return the sliding rails to their shortest position.

Note: When fully extended, the sliding rails will lock. The release mechanism is located on the sliding rail as shown. Press the release mechanism while pushing the sliding rails to shorten them.

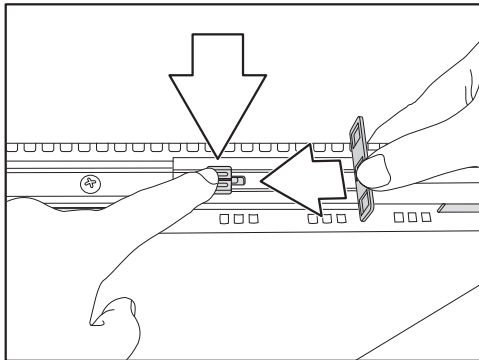

2.4 Rack mounting

6. With the rails in their shortest position, adjust both front mounting brackets so that they are flush with the front of the unit.

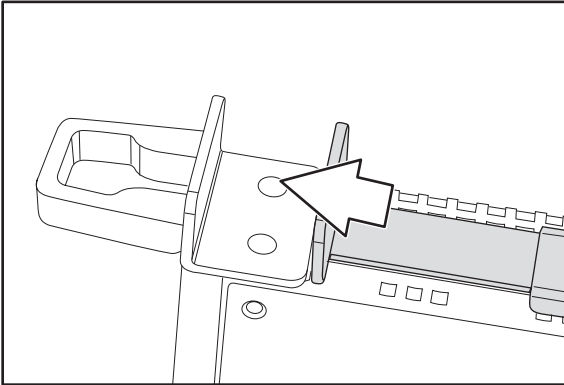

7. Accurately measure the depth of your rack and adjust the rear brackets accordingly.
8. When all brackets are positioned correctly, tighten them.
9. Lift the unit into place in the rack and screw it into place as shown.

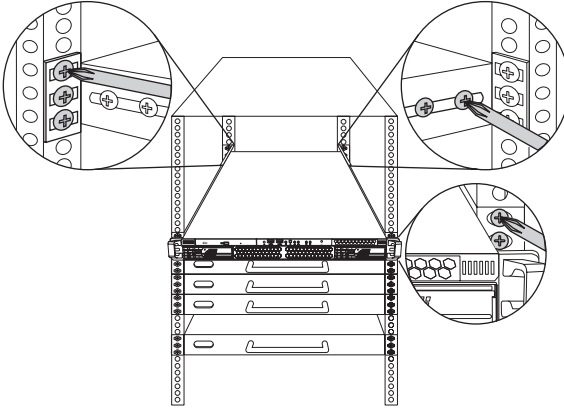

Note: To avoid injury, it is strongly recommended that two people lift the Transport GX21 into place while a third person screws it to the rack.

2.4 Rack mounting

Chapter 3: Replacing installed components

3.1 Introduction

This chapter describes how to replace all the pre-installed components of your Transport GX21 (B5350), including motherboard, CD-ROM drive, floppy disk drive and LED control board. There is also a section covering the replacement for two 1-port S-ATA backplanes.

Before you attempt to replace any components, make sure you have read section 2.1 *Before you begin*, in chapter 2, which describes the precautions you need to take and the tools you will require.

3.2 Replacing motherboard components

Follow these instructions to remove motherboard components and replace the motherboard.

3.2.1 Disconnecting all motherboard cables

When replacing the motherboard or certain motherboard components, it may be necessary to remove cables connected to the motherboard.

3.2 Replacing motherboard components

1. Disconnect power cables.

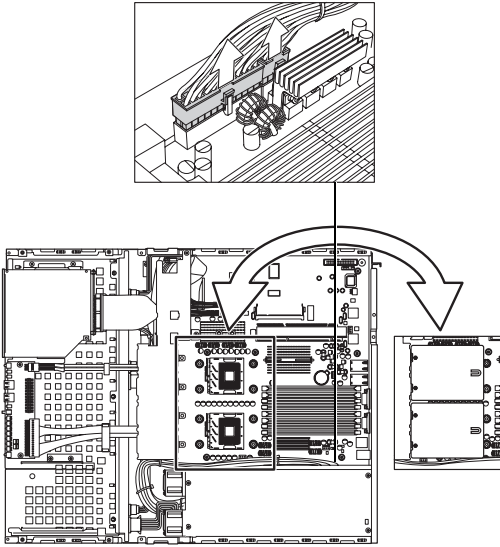

Note: There are two air ducts, leading from the fans, covering the CPUs.

2. Disconnect CD-ROM drive cable and S-ATA hard drive cable.

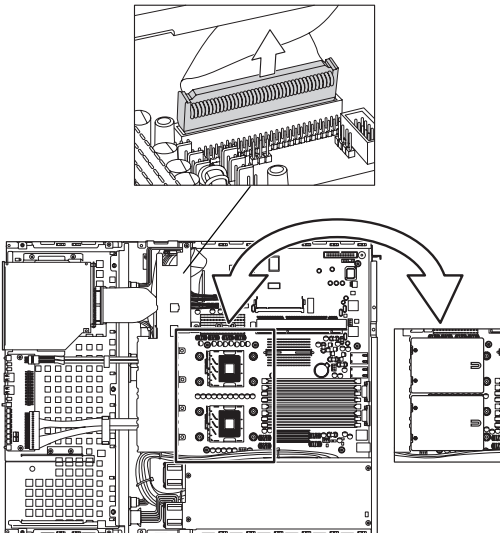

3.2 Replacing motherboard components

Note: If there is an FDD installed you will have to disconnect those cables too before you can remove the motherboard.

3. Disconnect front panel LED and USB connectors.
Front panel LED connector USB connector

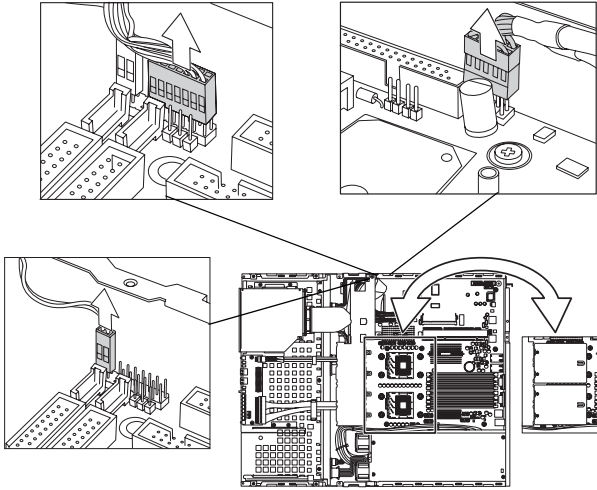

4. Remove fan and COM port connectors

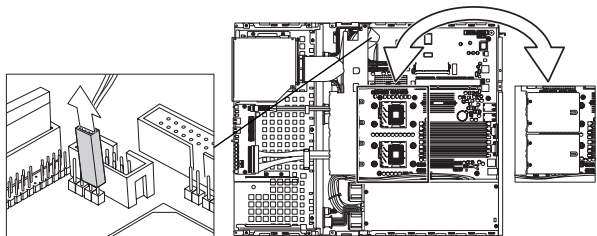

3.2 Replacing motherboard components

3.2.2 Replacing the motherboard

Follow these instructions to remove the motherboard from your Transport GX21 (B5350).

Note: Before removing the motherboard you must remove all cable connections to the motherboard. See section 3.2.1 *Disconnecting all motherboard cables* for details on how to do this.

1. Remove the two airducts covering the CPUs and the fan assembly bracket from the chassis.

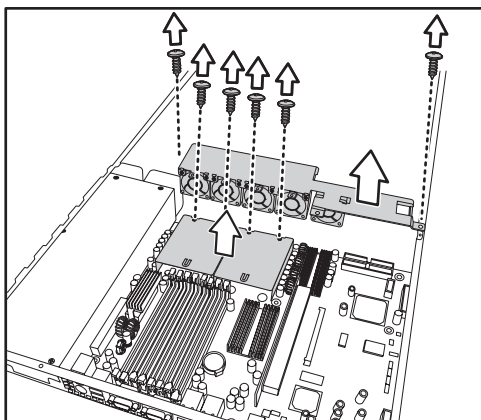

2. Remove the PCI retention bar.

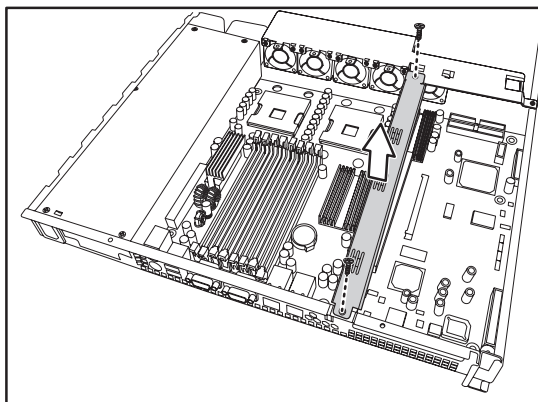

3.3 Replacing the CD-ROM drive

3. Remove the nine screws that secure the motherboard to the chassis.

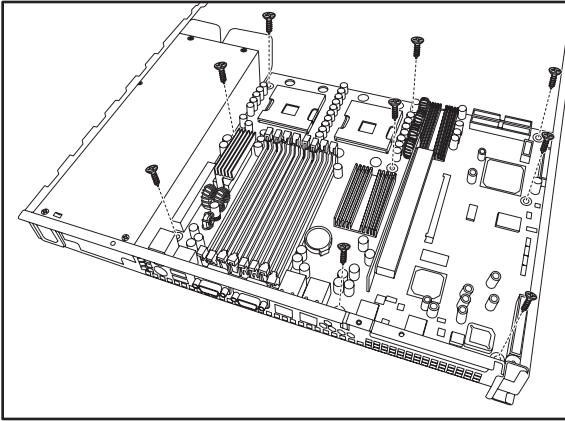

4. Remove the motherboard from the chassis.

3.3 Replacing the CD-ROM drive

This section describes how to remove and replace the CD-ROM drive in your Transport GX21 (B5350) system.

1. Remove the chassis cover as described in section 2.2.1 *Removing the chassis cover*.
2. Disconnect the CD-ROM power and data cables.
3. Remove the two screws that secure the CD-ROM to the chassis.

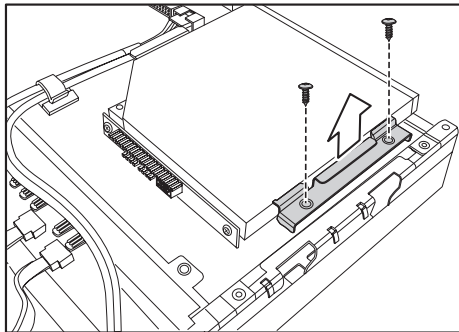

3.4 Replacing the LED control board

4. Remove the two screws that secure the CD-ROM backplane to the CD-ROM drive.

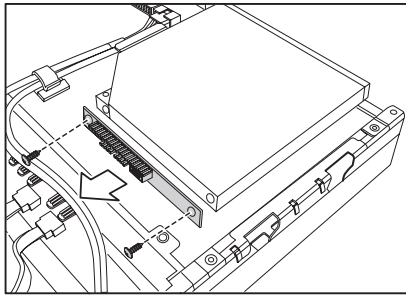

5. Lift the drive from the chassis.

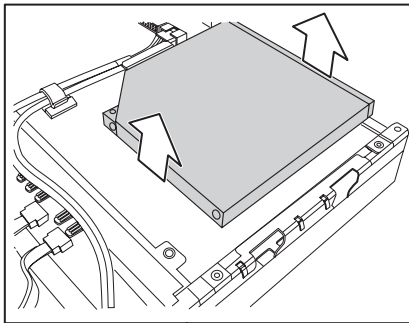

3.4 Replacing the LED control board

Follow these instructions to replace the LED control board.

3.5 Replacing the storage backplane

1. Remove the front panel ribbon cable from the rear of the LED control panel.

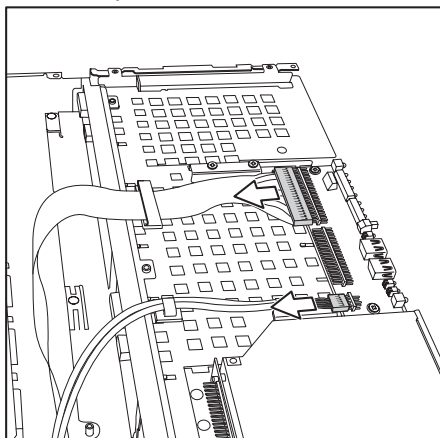

2. Remove the two screws that secure the LED control panel to the chassis and lift the board free of the chassis.

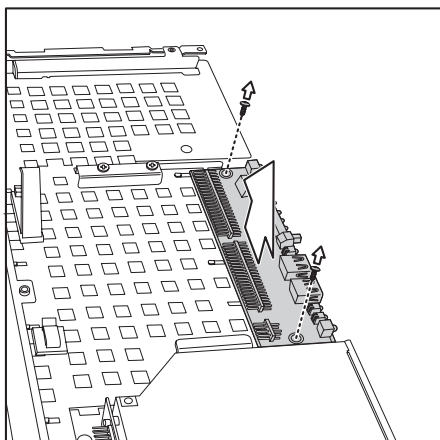

3.5 Replacing the storage backplane

This section describes how to replace the S-ATA backplane on your Transport GX21 (B5350).

1. Remove the chassis cover as described in section 2.2.1 *Removing the chassis cover*.
2. Remove all cables connected to the S-ATA backplane, including power cables, and S-ATA data cables.

3.5 Replacing the storage backplane

Note: You must remove the CD-ROM, front panel and FDD cables before removing the backplane. See 3.2 *Replacing motherboard components* for details on how to do this.

3. Remove the three screws that secure the S-ATA backplane bracket to the chassis.

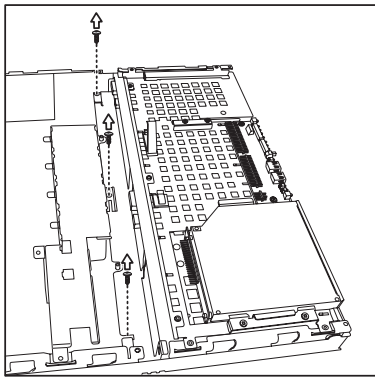

4. Remove the S-ATA backplane bracket and backplanes free from the chassis.

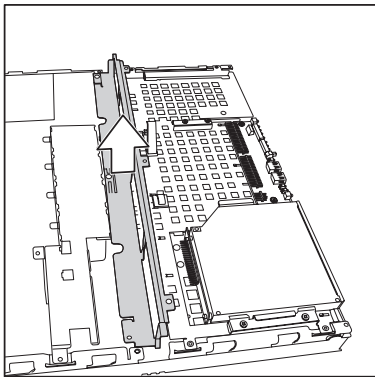

5. Remove the six screws that secure the S-ATA backplane to the bracket.
6. Remove the S-ATA backplane.

3.5 Replacing the storage backplane

3.5.0.1 S-ATA backplane features

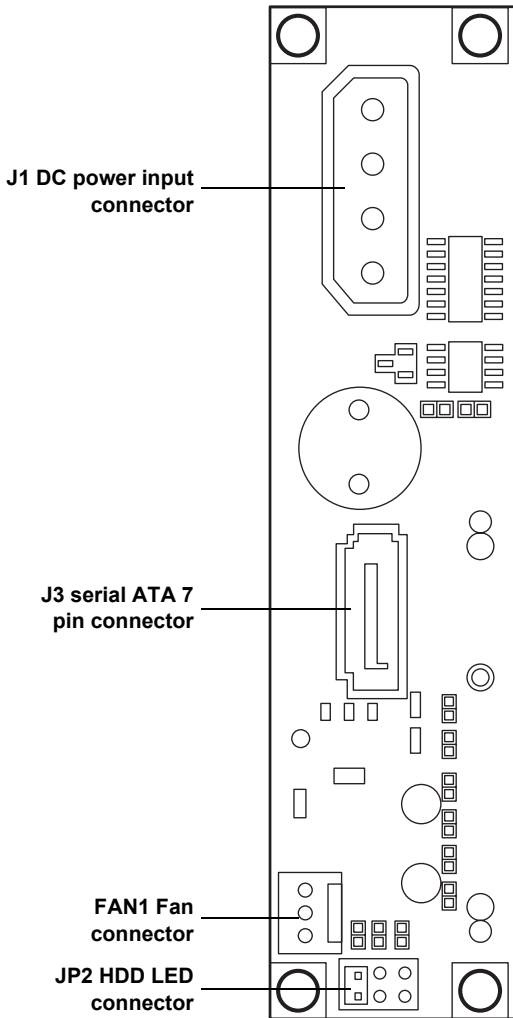

Note: *B5350G21S2H* is shipped with two 1-port S-ATA backplanes to support 2 hot-swap S-ATA hard disk drives

3.6 Replacing the power supply

3.6 Replacing the power supply

Follow these instructions to replace the power supply in your Transport GX21 (B5350) system.

1. Remove the chassis cover as described in section 2.2.1 *Removing the chassis cover*.
2. Disconnect power cables from the motherboard, backplanes, FDD, CD-ROM drive and fans. See 2.3 *Installing a hard drive*, 3.2.1 *Disconnecting all motherboard cables*, section 3.3 *Replacing the CD-ROM drive*, 3.5 *Replacing the storage backplane*, and section 3.4 *Replacing the LED control board* for details on how to do this.
3. Remove the two screws that secure the power supply to the chassis and lift the unit free.

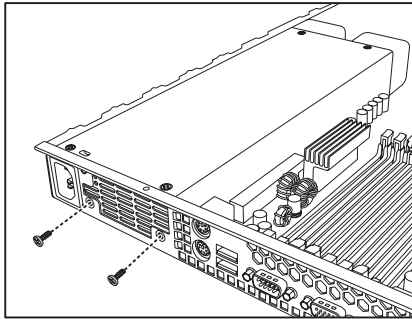

3.7 Replacing the cooling fans

Follow these instructions to replace the cooling fans in your Transport GX21 (B5350) system.

1. Remove the chassis cover as described in section 2.2.1 *Removing the chassis cover*.
2. Remove the PCI retention bar

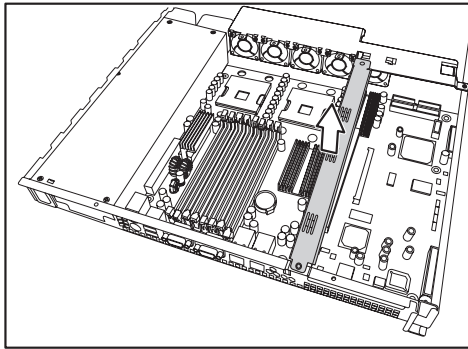

Note: You may need to cut the cable ties that secure the fan power cables before attempting to unplug them.

3. Remove the power cables for the 5 fans from the motherboard.
4. Remove the two screws that secure the fan bracket to the chassis.
5. Lift the fan bracket free of the unit

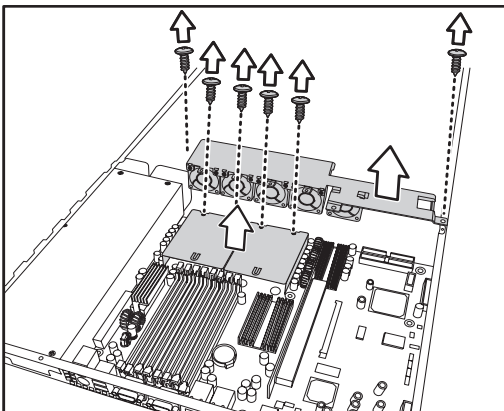

3.7 Replacing the cooling fans

6. Remove the four screws securing each fan to the fan bracket to remove them from the fan bracket.

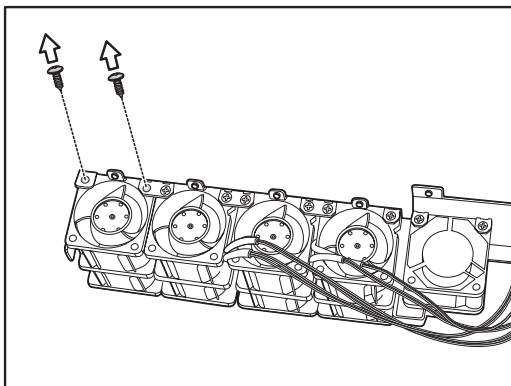

Note: The Transport GX21 (B5350) uses two different types of cooling fans which operate at different speeds. The fan installed nearest the power supply has a peak speed of 15,000 rpm. The other 4 fans have a peak speed of 15,500 rpm. The fan nearest the power supply should be connected to the speed-controllable pin header (CPU1_FAN) on the mother board.

BIOS

Introduction

Your Transport GX21 (B5350) system includes a powerful Tiger i7320R S5350 motherboard with Phoenix BIOS on 8 MBit flash ROM.

The BIOS is the motherboard's basic input/output system. The BIOS contains all the settings required to control the keyboard, display, disk drives, serial communications, and a number of miscellaneous functions. This section of the appendix describes the various BIOS settings that can be used to configure your system.

BIOS setup utility

With the BIOS setup utility, you can modify BIOS settings and control the features of your system. The setup utility uses a number of menus.

Note: All menus shown in this section are based on a typical system. The actual menus displayed on your screen may look different depending on the hardware and features installed.

To start the BIOS setup utility:

1. Turn on or reboot your system.
2. Press during POST (F4 on remote console) to start the BIOS setup utility.

BIOS setup utility

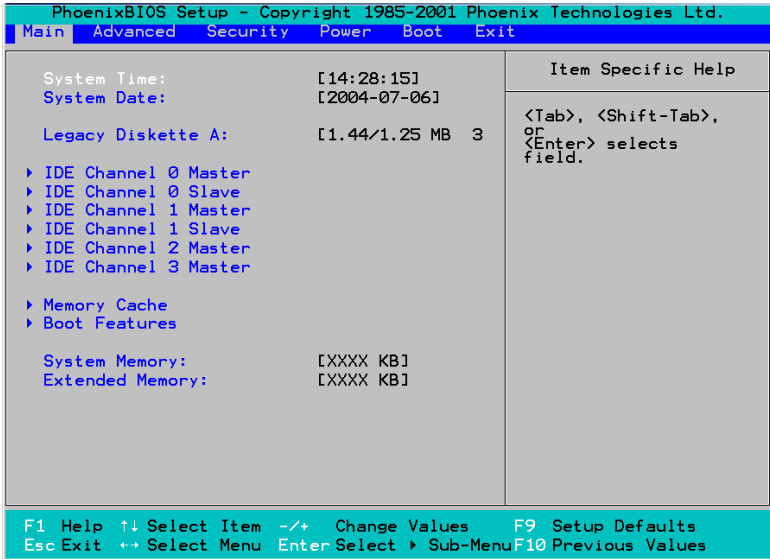

To select an item:

Use the <Arrow> keys to make a selection.

To display a submenu (a pointer ► marks all submenus)

Use the arrow keys to move the cursor to the required submenu and press <Enter>.

BIOS menu bar

The menu bar at the top of the window lists the following selections:

Menu bar selections

Main	Configure basic system setup options
Advanced	Configure advanced chipset options
Security	Configure user and supervisor passwords
Power	Configure power management
Boot	Configure system boot order
Exit	Exit setup utility

Note: Options written in **bold type** represent the BIOS setup default.

BIOS legend bar

The following chart describes the legend keys and their functions.

Key	Function
<F1>	General help window
<ESC>	Exit current window
←→ arrow keys	Move between menus
↑↓ arrow keys	Move cursor up/down
<Tab> or <Shift-Tab>	Select submenu
<Home> or <End>	Move cursor to the top or bottom of the window
<PgUp> or <PgDn>	Move cursor to the next or previous page
<Plus> or <Minus>	Change value
<F9>	Load setup default configuration values
<F10>	Save and exit
<Enter>	Select submenu

BIOS main menu

The Main BIOS menu is the first screen that appears when you enter BIOS setup. The menu has two main frames. The left frame displays all the options that can be configured. "Grayed-out" options cannot be configured, options in blue can be changed.

The right frame displays the key legend. Above the key legend is an area reserved for a text message. When an option is selected in the left frame, it is highlighted in white. Often, a text message will accompany it.

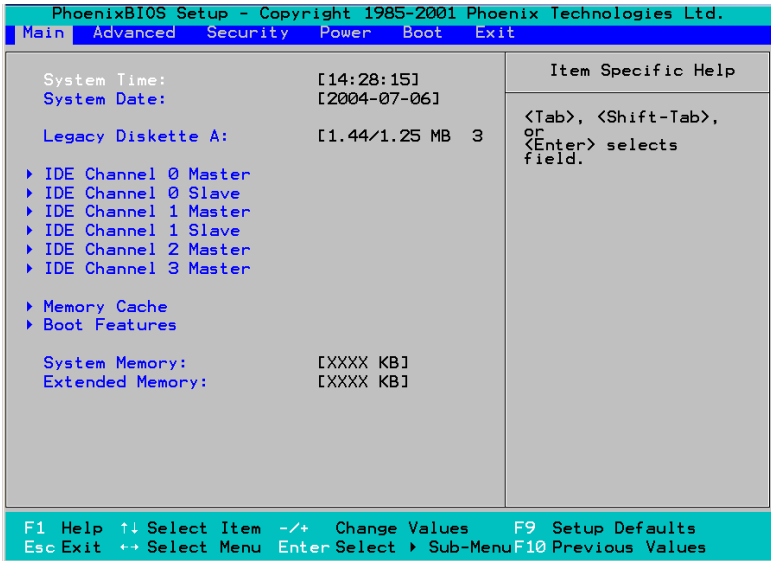

Feature	Option	Description
System Time	HH:MM:SS	Set the system time
System Date	MM:DD:YY	Set the system date
Legacy Diskette A:	NONE / 360 K, 5.25 in / 1.2 M, 5.25in / 720K, 3.5 in / 1.44 M, 3.5 in / 2.88, 3.5 in	Set the floppy drive type
IDE Channel	submenu	Set IDE drive configuration
Memory Cache	submenu	Set memory caching
Boot Features	submenu	Set boot options
System Memory		Set system memory
Extended Memory		Set extended memory

IDE channel submenus

You can use this screen to change IDE Configuration Settings.

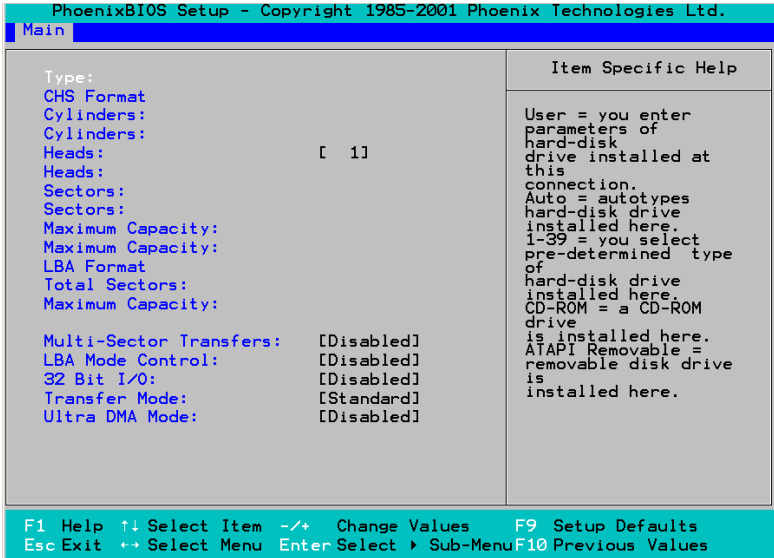

Feature	Option	Description
Cylinders		Set number of cylinders on disk
Heads		Set number of heads on disk
Sectors		Set number of sectors on disk
Maximum Capacity		Set maximum size of disk
Multi-Sector Transfers	Disabled / 2 sectors 4 sectors / 8 sectors 16 sectors	Set number of sectors per block for multiple sector transfers
LBA Mode Control	Enabled / Disabled	Set LBA on or off
32-bit I/O	Enabled / Disabled	Set 32-bit I/O on or off
Transfer Mode	Auto / Standard Fast PIO 1 / Fast PIO 2 / Fast PIO 3 / Fast PIO 4 / FPIO 3 / DMA 1 / FPIO 4 / DMA 2	Set transfer mode for data to disk
Ultra DMA Mode	Disabled / Mode 0 / Mode 1 / Mode 2	Set Ultra DMA mode

Note: Selecting **Auto** will automatically detect IDE settings.

Memory cache

You can use this screen to change memory caching settings

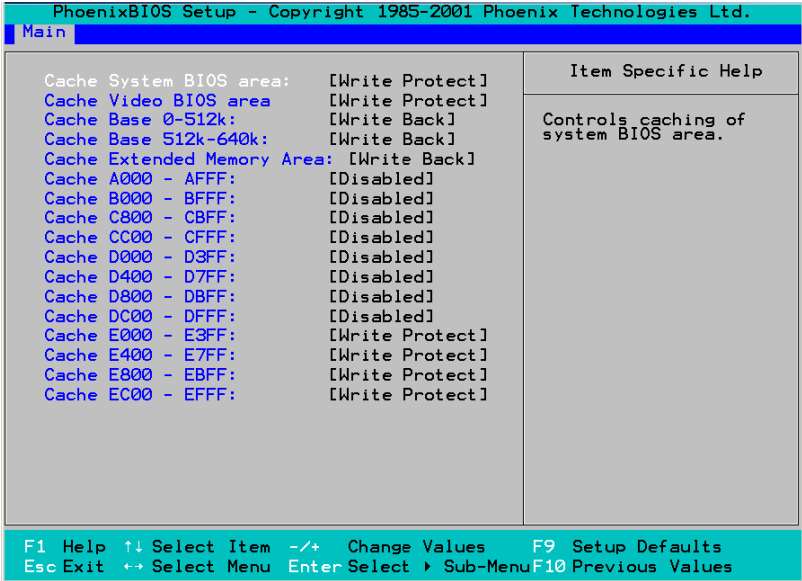

Feature	Option	Description
Cache System BIOS area	NULL / Write Protect	Cache system BIOS ROM (shadowing must be enabled)
Cache Video BIOS area	NULL / Write Protect	Cache video BIOS ROM (Shadowing must be enabled)

Boot features

You can use this screen to set boot parameters.

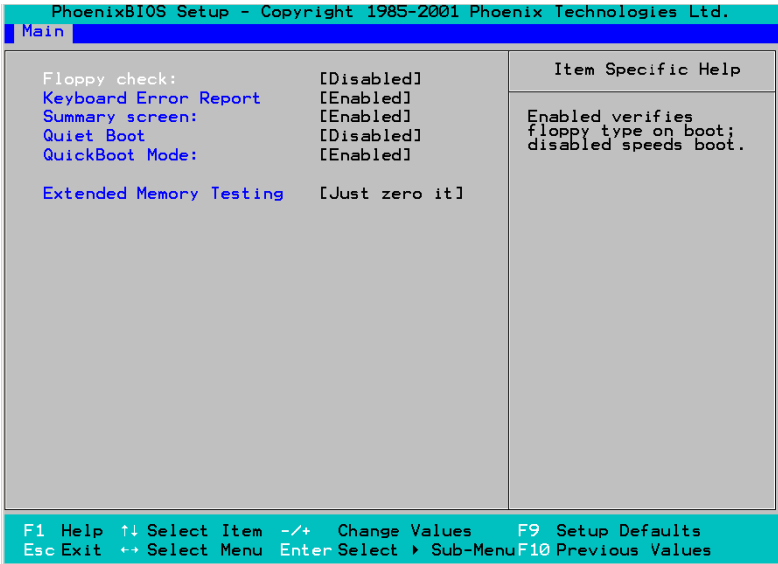

Feature	Option	Setting
Floppy Check	Enabled / Disabled	Set check for floppy disk at POST on or off
Summary Screen	Enabled / Disabled	Set a summary of BIOS settings at POST on or off
Quiet Boot	Enabled / Disabled	Set the OEM logo during boot up on or off
QuickBoot Mode	Enabled / Disabled	Speed up booting by shortening test procedure
Extended Memory Testing	Normal / Just zero it / None	Set test for extended memory at POST

BIOS advanced menu

You can use this menu to configure advanced BIOS settings.

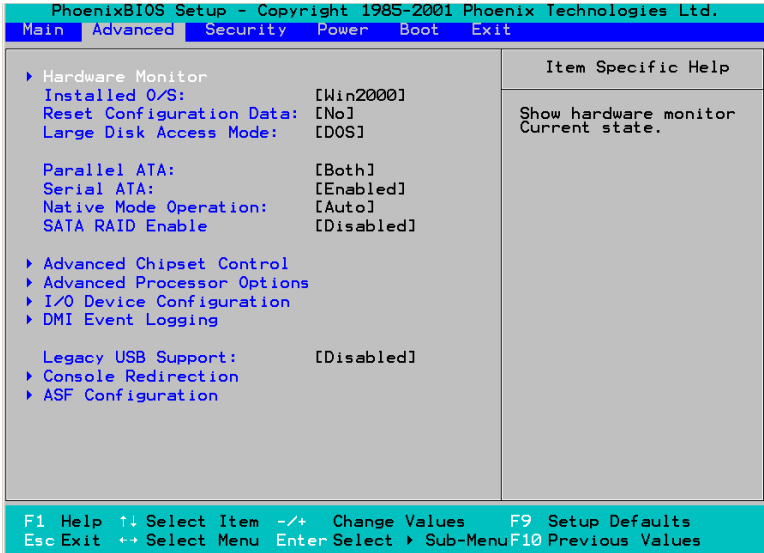

Features	Option	Description
Hardware Monitor	submenu	Set hardware monitor options
Enable ACPI	Yes / No	
Installed OS	Other / Win95 / Win98 / WinMe / Win2000	Set the installed operating system Note: Incorrect settings may cause the system to behave unpredictably.
Reset Configuration Data	Yes / No	Force BIOS to discard old configuration and re-detect hardware
Large Disk Access Mode	DOS / Other	Set access mode for disks over C1024 H16 S64
Parallel ATA	Preliminary / Secondary / Both	Set controller for parallel ATA devices
Serial ATA	Enabled / Disabled	Set booting from S-ATA devices on or off

Features	Option	Description
Native Mode Operation	Auto / Parallel ATA / Serial ATA / Both	Set S-ATA devices to operate in native or emulated mode
SATA RAID Enable	Enabled / Disabled	Set RAID BIOS loading on start up
Advanced Chipset Control	submenu	Configures USB controller and legacy device support
Advanced Processor Options	submenu	Set advanced processor options
I/O Device Configuration	submenu	Configure I/O devices
DMI Event Logging	submenu	Set DMI event logging
Legacy USB Support	Enabled / Disabled	Set control of USB ports for operating systems that do not support USB

Hardware monitor

You can use this screen to change critical system settings.

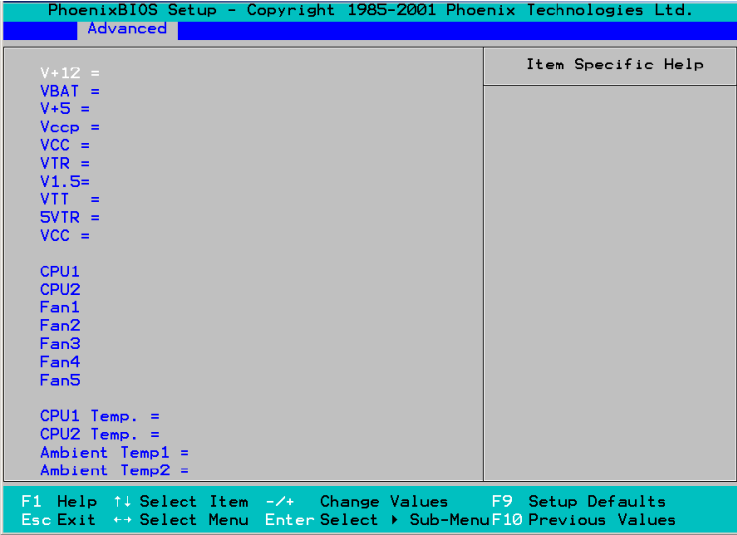

Advanced chipset control submenu

Use this screen to fine tune the chipset.

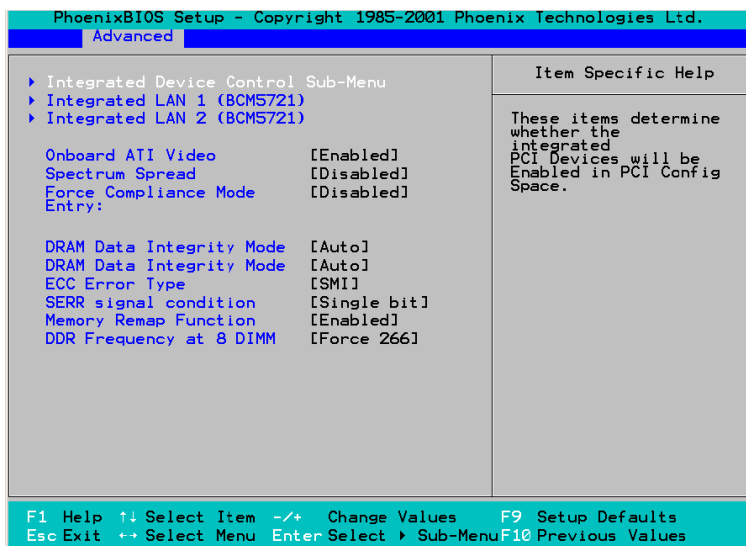

Feature	Option	Description
Integrated Device Control Sub-Menu	submenu	
Integrated LAN 1	submenu	
Integrated LAN 2	submenu	
Spectrum Spread		
Force Compliance Mode Entry	Enabled Disabled	Set PCI-E compliance mode
DRAM Data Integrity Mode	Disabled 72-bit ECC 144-bit ECC Auto	Set ECC mode for ECC memory modules
ECC Error Type	None / NMI / SMI / SCI	Set the type of interrupt generated when an ECC error occurs
SERR Signal Condition	None Single bit Multiple bit Both	Set the error conditions on which SERR is sent

Feature	Option	Description
Memory Remap Function	Enabled Disabled	Remap BIOS memory to above 1 MB (BIOS cannot be shadowed when this is enabled)

Integrated Device Control Submenu

Use this screen to control USB.

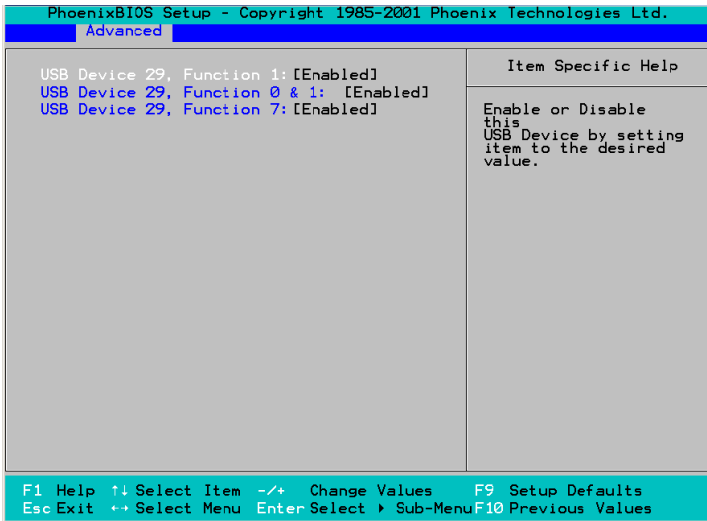

Feature	Option	Description
USB Device 29 Function	Enabled/Disabled	Set functions of USB on or off

Integrated LAN 1 and 2 submenus

You can use these screens to set options for the integrated LANs.

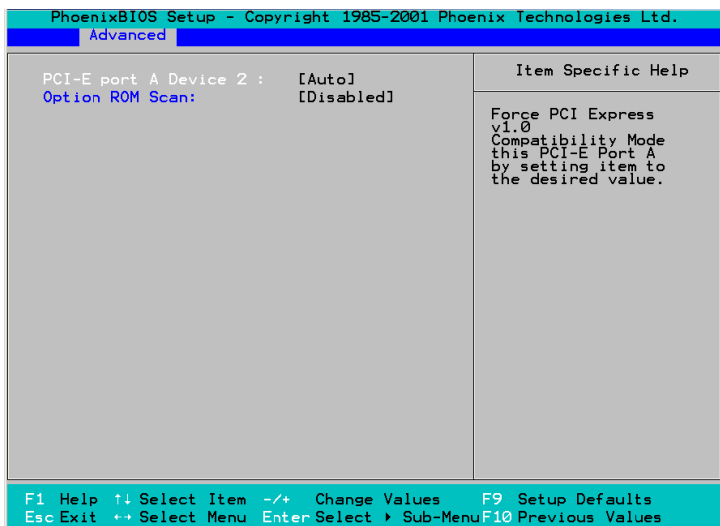

Feature	Option	Description
PCI-E port	Auto / Disabled / Enabled / Force PCI Express v1.0 Compatibility Mode	Set PCI-E compatibility mode
Option ROM Scan	Enabled / Disabled	Initialize device expansion ROM

Advanced Processor Control submenu

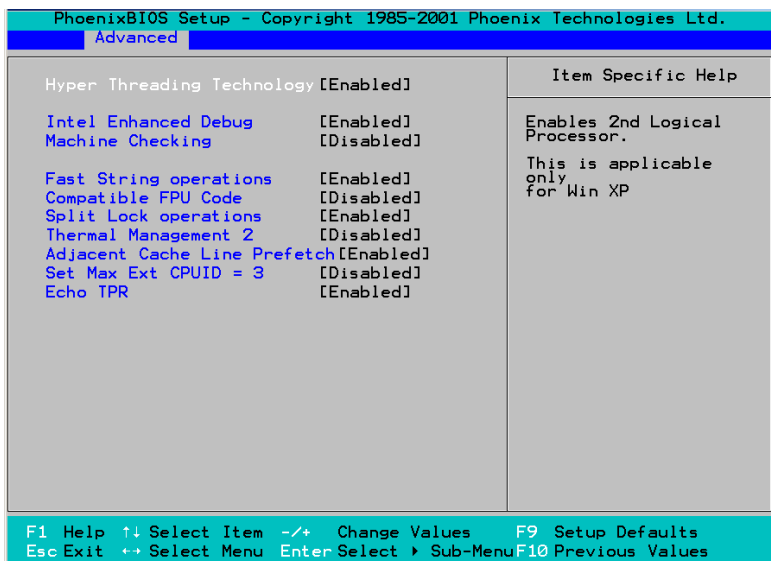

Feature	Option	Description
Hyper Threading Technology	Enabled Disabled	Enable Hyper-Threading (only if supported by processor)
Thermal Management 2	Enabled Disabled	Prevent damage to the CPUs by slowing the processor. Full speed resumes when a stable temperature is reached
Set Max Ext CPUID=3	Enabled Disabled	Set the Max CPUID extended function value to 3

I/O Device Configuration submenu

You can use this screen to configure I/O Devices.

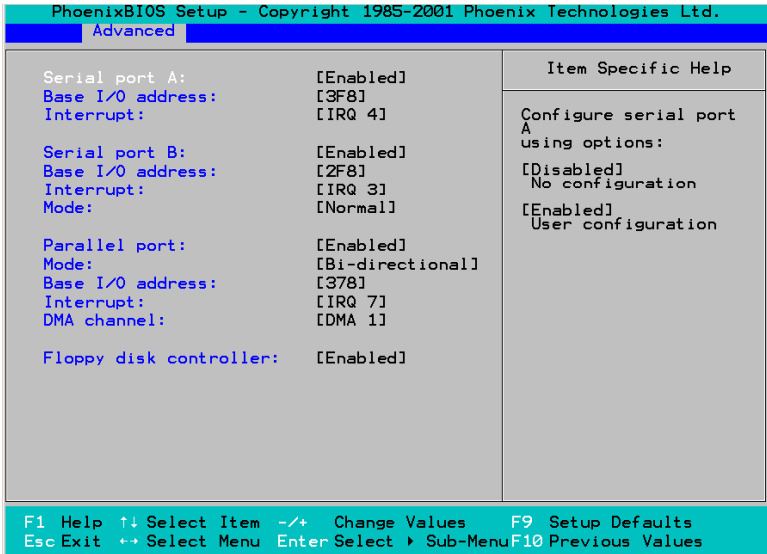

Feature	Option	Description
Serial port A	Enabled / Disabled	Turn serial port A on or off
Base I/O address	3F8 / 2F8 / 3E8 / 2E8	Set the base I/O address for serial port A
Interrupt	IRQ3 / IRQ4	Set the interrupt for serial port A
Serial port B	Enabled / Disabled	Turn serial port B on or off
Base I/O address	3F8 / 2F8 / 3E8 / 2E8	Set the base I/O address for serial port B
Interrupt	IRQ3 / IRQ4	Set the interrupt for serial port B
Mode	Normal / IrDA / ASK-IR	Set the mode for the type of device to be attached to serial port B
Parallel Port	Enabled / Disabled	Turn the parallel port on or off
Mode	SPP / EPP / EC	Set the mode for the type of device to be attached to the parallel port
Base I/O and Interrupt	Disabled 378/IRQ7 278/IRQ5 3BC/IRQ7	Set the base I/O address and interrupt for the parallel port

Feature	Option	Description
DMA Channel	DMA 1 / DMA 3	Set the DMA channel for the parallel port
Floppy disk controller	Enabled / Disabled	Set the Floppy Disk on or off

DMI Event Logging submenu

Use this screen to set DMI event-logging options.

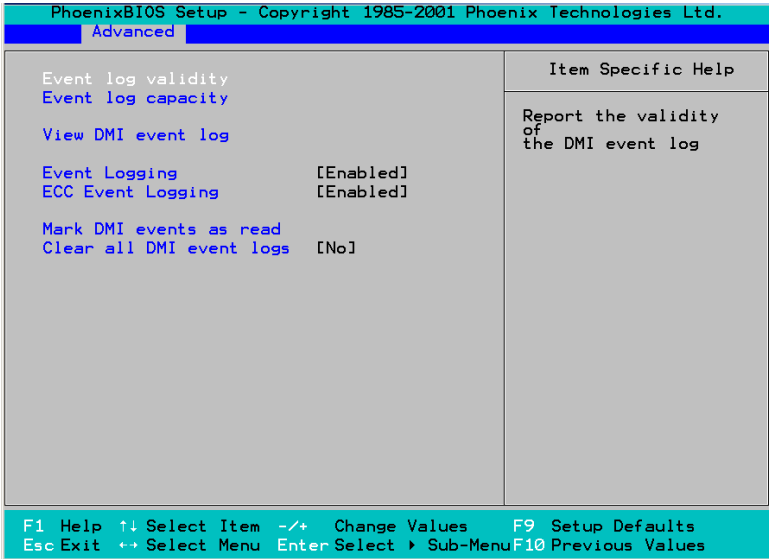

Feature	Option	Description
Event Logging	Enabled / Disabled	Set DMA Logging on or off
ECC Event Logging	Enabled / Disabled	Set ECC Logging on or off
Clear all DMI event logs	Yes / No	Clear all DMI logs after rebooting

Console Redirection submenu

Use this screen to set options for external control using a console.

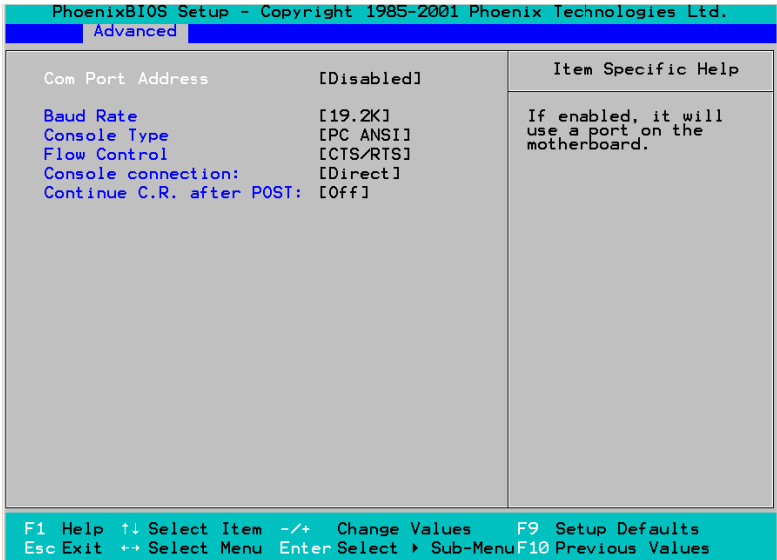

Feature	Option	Description
Com Port Address	Disabled / On-board COM A / On-board COM B / NULL	Enable onboard COM ports for external console use
Baud Rate	300 / 1200 / 2400 / 9600 / 19.2K / 38.4K / 57.6K / 115.2K	Set the baud rate for the COM port
Console Type	VT100 / VT100,8bit / PC-ANSI , 7bit / PC ANSI / VT100+ / VT- UTF8 / NULL	Set the console type
Flow Control	NULL / XON/XOFF / CTS/RTS	Enable flow control
Console Connection	Direct / Via modem	Set modem or direct connection
Continue C.R. after POST	On / Off	Enable console redirection after the operating system has loaded

ASF Configuration submenu

You can use this screen to set ASF options.

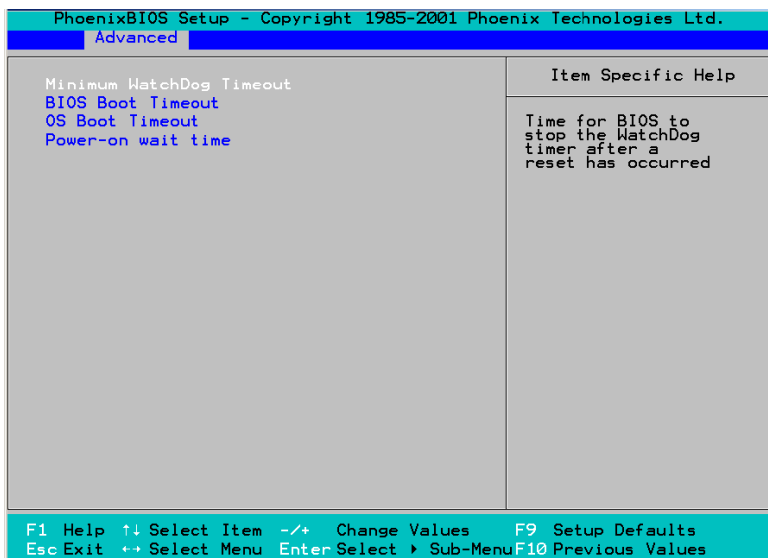

Feature	Option	Description
Minimum Watchdog Timeout		Set the time for BIOS to stop the Watchdog Timer after a reset has occurs
BIOS Boot Timeout		Set time for BIOS to boot before the system is reset
OS Boot Timeout		Time for OS to boot before system is reset
Power-on wait time		Set maximum amount of time for Alert Sending Device to connect with its transport media

Security menu

You can use this screen to set security options for your computer.

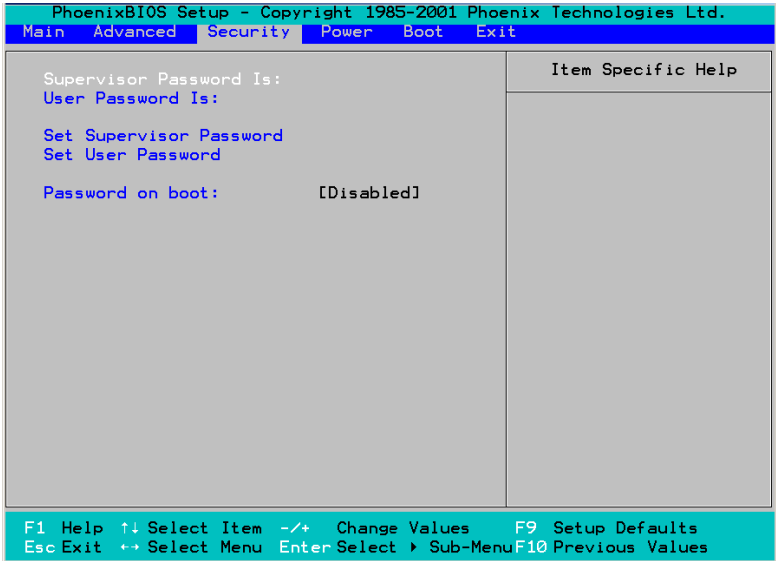

Feature	Option	Description
Set Supervisor Password		Set the supervisor password which restricts access to the BIOS
Set User Password		Set user password
Password on boot		Set system to ask for password at start up. Failure to enter the correct password within three attempts will result in system shutdown

Power menu

You can use this screen to configure power management.

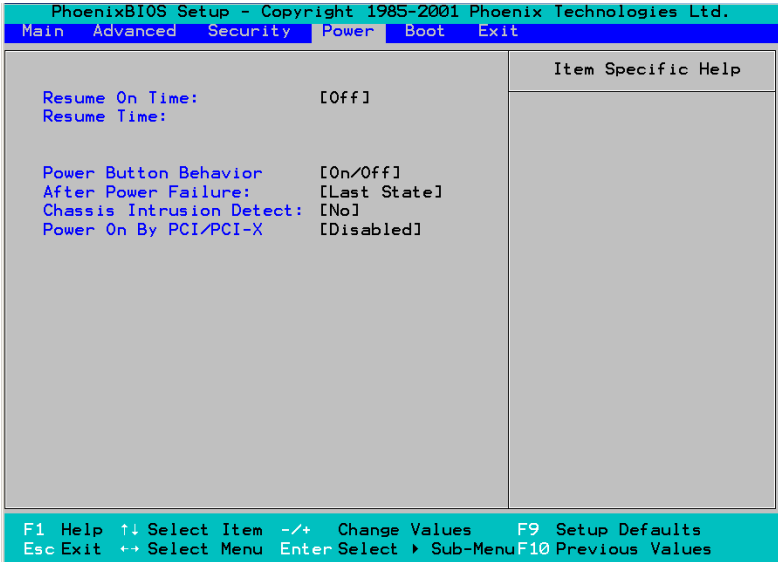

Feature	Option	Description
Resume On Time	On / Off	Set a time for the system to automatically power on
Power Button Behavior	On/Off Wake/Sleep	Set power button to switch power on and off or sleep and wake up
After power Failure	Enabled Disabled	Set the system to return to previous state or stay powered off after a power failure
Chassis Intrusion Detect	Enabled Disabled	Set BIOS to record chassis intrusion events
Power On By PCI/PCI-X	Enabled Disabled	Set system to wake up from sleep mode on PCI card input

Boot menu

You can use this screen to set boot up options.

PhoenixBIOS Setup - Copyright 1985-2001 Phoenix Technologies Ltd.	
Main Advanced Security Power Boot Exit	
<ul style="list-style-type: none">▶ Removable Devices▶ Hard Drives CD-ROM Drive Network Boot	<p style="text-align: center;">Item Specific Help</p> <p>Keys used to view or configure devices: <Enter> expands or collapses devices with a + or - <Ctrl+Enter> expands all <Shift + 1> enables or disables a device. <+> and <-> moves the device up or down. <n> May move removable device between Hard Disk or Removable Disk <d> Remove a device that is not installed.</p>
F1 Help ↑↓ Select Item -/+ Change Values F9 Setup Defaults Esc Exit ←→ Select Menu Enter Select ▶ Sub-Menu F10 Previous Values	

Exit menu

You can use this screen to save or discard changes and load factory defaults.

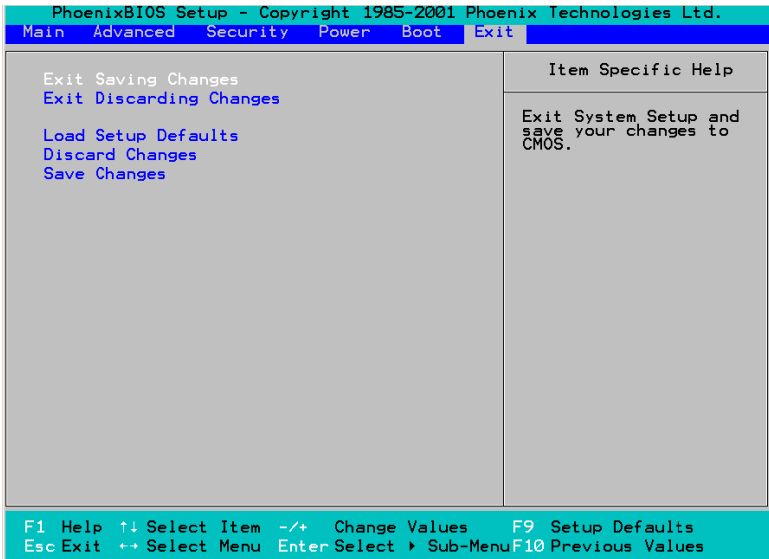

Feature	Option	Description
Exit Saving Changes		Save changes made and exit BIOS
Exit Discarding Changes		Discard changes made and exit BIOS
Load Setup Defaults		Restore all BIOS settings to factory defaults
Discard Changes		Restores settings to previous values
Save Changes		Saves settings at their current values

Technical support

If a problem arises with this system, you should consult your dealer first for help. The system is likely to have been configured by your dealer, making him the most appropriate choice when seeking technical advice. Your dealer may also be close enough to visit with the hardware for servicing or testing.

Help resources:

1. See the TYAN website for FAQs, bulletins, driver updates and other information: <http://www.tyan.com>
2. Only contact TYAN after first speaking with your dealer
3. Check the TYAN user group:
alt.comp.periphs.mainboard.TYAN

Returning merchandise for service

If any problems occur during the product's warranty period, consult your system vendor or distributor before contacting TYAN. The warranty covers normal customer use of the product. The warranty does not cover damages sustained during shipping or failure due to alteration, misuse, abuse, or improper maintenance of the unit.

Note: A receipt or copy of your invoice, marked with the date of purchase, is required before any warranty service can be provided. You may obtain service by calling the manufacturer for a Return Merchandise Authorization (RMA) number. The RMA number should be displayed prominently on the outside of the shipping carton, and the package should be mailed prepaid. TYAN will pay to have the product shipped back to you.

Transport GX21 (B5350) User's Manual.

